

Dimensions for HGW Series

HGW-CA
HGW-HA

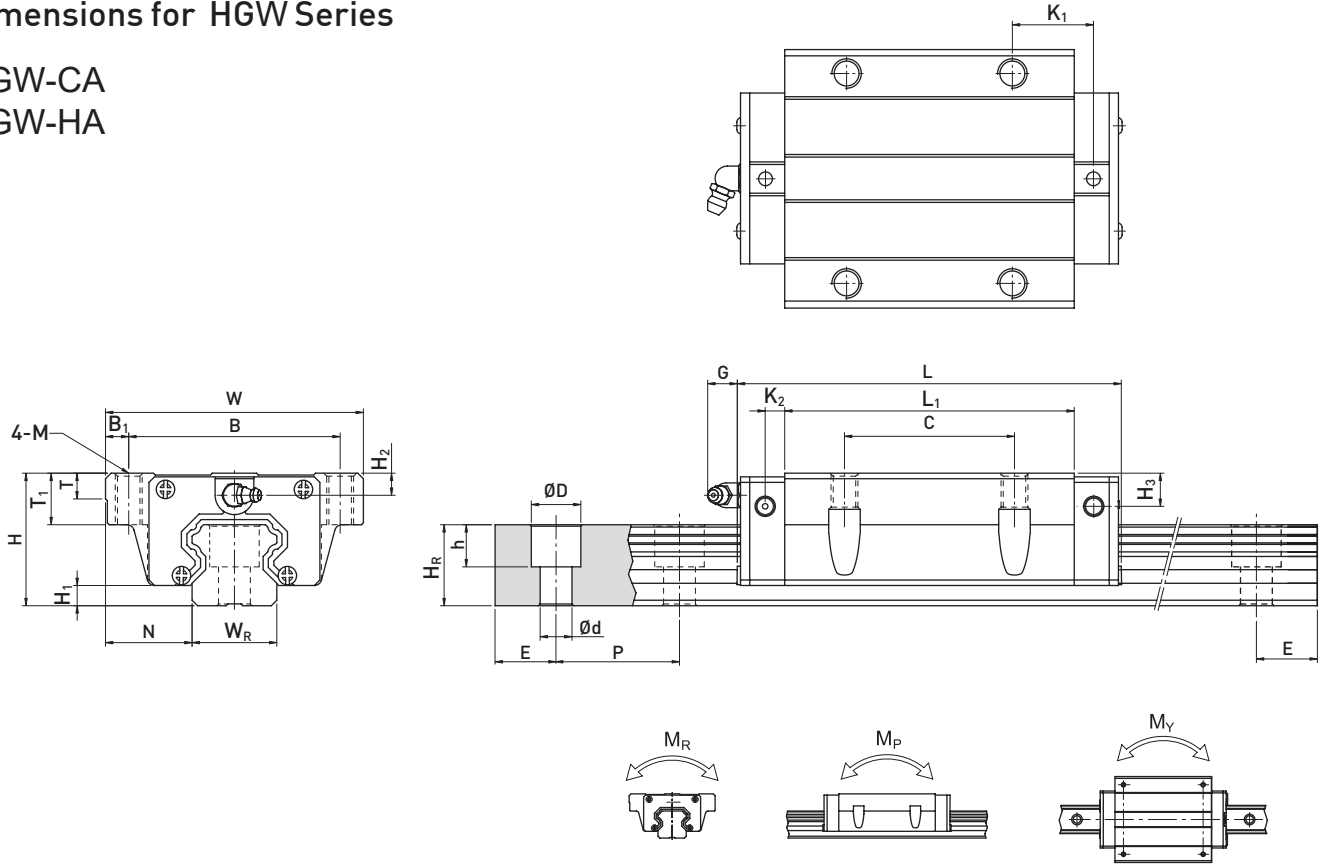

Model No.	Dimensions of Assembly (mm)		Dimensions of Block (mm)															Dimensions of Rail (mm)						Mounting Bolt for Rail (mm)	Basic Dynamic Load Rating C(kN)	Basic Static Load Rating C ₀ (kN)	Static Rated Moment			Weight		
	H	H ₁	N	W	B	B ₁	C	L ₁	L	K ₁	K ₂	G	M	T	T ₁	H ₂	H ₃	W _R	H _R	D	h	d	P				E	M _R (kN-m)	M _P (kN-m)	M _Y (kN-m)	Block (kg)	Rail (kg/m)
	HGW15CA	24	4.3	16	47	38	4.5	30	39.4	61.4	8	4.85	5.3	M5	6	8.9	3.95	3.7	15	15	7.5	5.3	4.5	60	20	M4x16	11.38	16.97	0.12	0.10	0.10	0.17
HGW20CA	30	4.6	21.5	63	53	5	40	50.5	77.5	10.25	6	12	M6	8	10	6	6	20	17.5	9.5	8.5	6	60	20	M5x16	17.75	27.76	0.27	0.20	0.20	0.40	2.21
HGW20HA								65.2	92.2	17.6																21.18	35.90	0.35	0.35	0.35	0.52	
HGW25CA	36	5.5	23.5	70	57	6.5	45	58	84	10.7	6	12	M8	8	14	6	5	23	22	11	9	7	60	20	M6x20	26.48	36.49	0.42	0.33	0.33	0.59	3.21
HGW25HA								78.6	104.6	21																32.75	49.44	0.56	0.57	0.57	0.80	
HGW30CA	42	6	31	90	72	9	52	70	97.4	14.25	6	12	M10	8.5	16	6.5	10.8	28	26	14	12	9	80	20	M8x25	38.74	52.19	0.66	0.53	0.53	1.09	4.47
HGW30HA								93	120.4	25.75																47.27	69.16	0.88	0.92	0.92	1.44	
HGW35CA	48	7.5	33	100	82	9	62	80	112.4	14.6	7	12	M10	10.1	18	9	12.6	34	29	14	12	9	80	20	M8x25	49.52	69.16	1.16	0.81	0.81	1.56	6.30
HGW35HA								105.8	138.2	27.5																60.21	91.63	1.54	1.40	1.40	2.06	
HGW45CA	60	9.5	37.5	120	100	10	80	97	139.4	13	10	12.9	M12	15.1	22	8.5	20.5	45	38	20	17	14	105	22.5	M12x35	77.57	102.71	1.98	1.55	1.55	2.79	10.41
HGW45HA								128.8	171.2	28.9																94.54	136.46	2.63	2.68	2.68	3.69	
HGW55CA	70	13	43.5	140	116	12	95	117.7	166.7	17.35	11	12.9	M14	17.5	26.5	12	19	53	44	23	20	16	120	30	M14x45	114.44	148.33	3.69	2.64	2.64	4.52	15.08
HGW55HA								155.8	204.8	36.4																139.35	196.20	4.88	4.57	4.57	5.96	
HGW65CA	90	15	53.5	170	142	14	110	144.2	200.2	23.1	14	12.9	M16	25	37.5	15	15	63	53	26	22	18	150	35	M16x50	163.63	215.33	6.65	4.27	4.27	9.17	21.18
HGW65HA								203.6	259.6	52.8																208.36	303.13	9.38	7.38	7.38	12.89	

Note : 1 kgf = 9.81 N